

INSTRUCTIONS BED FRAME

No.	Part No.	Description	Quantity
1	SMW-0132	Bed Strut Vertical Front	2
2	SMW-0134 LH	Bed Strut Vertical Rear LH	1
3	SMW-0134 RH	Bed Strut Vertical Rear RH	1
4	SMW-0136	Bed Mounting Bracket	2
5	SMW-0138	Bed Frame Bracket Front	2
6	SMW-0139	Bed Frame Bracket Central	2
7	SMW-0141	Bed Strut Rivnut Plate A	4
8	SMW-0142	Bed Strut Rivnut Plate B	2
9	Tube A LH	Side Beam LH	1
10	Tube A RH	Side Beam RH	1
11	Tube B	Front Beam	1
12	Tube C	Centre Beam	2
13	Tube D	Rear Beam	1
14	M-0013	Spacer	2
15	Rivet	4 x 12mm	4
16	CSK Rivet	4 x 8mm	32
17	Self Tapping Pan Screw	4.2 x 13mm	6
18	Penny Washer	M6	16
19	Penny Washer	M8	6
20	Washer	M8	40
21	Button Head Bolt	M6 x 20mm	16
22	Button Head Bolt	M8 x 20mm	28
23	Button Head Bolt	M8 x 40mm	4
24	Button Head Bolt	M8 x 80mm	2
25	Nyloc Nut	M8	12

What's in the box?

The various kit options and their parts are noted in the table with a diagram on the following pages.

INSTRUCTIONS BED FRAME

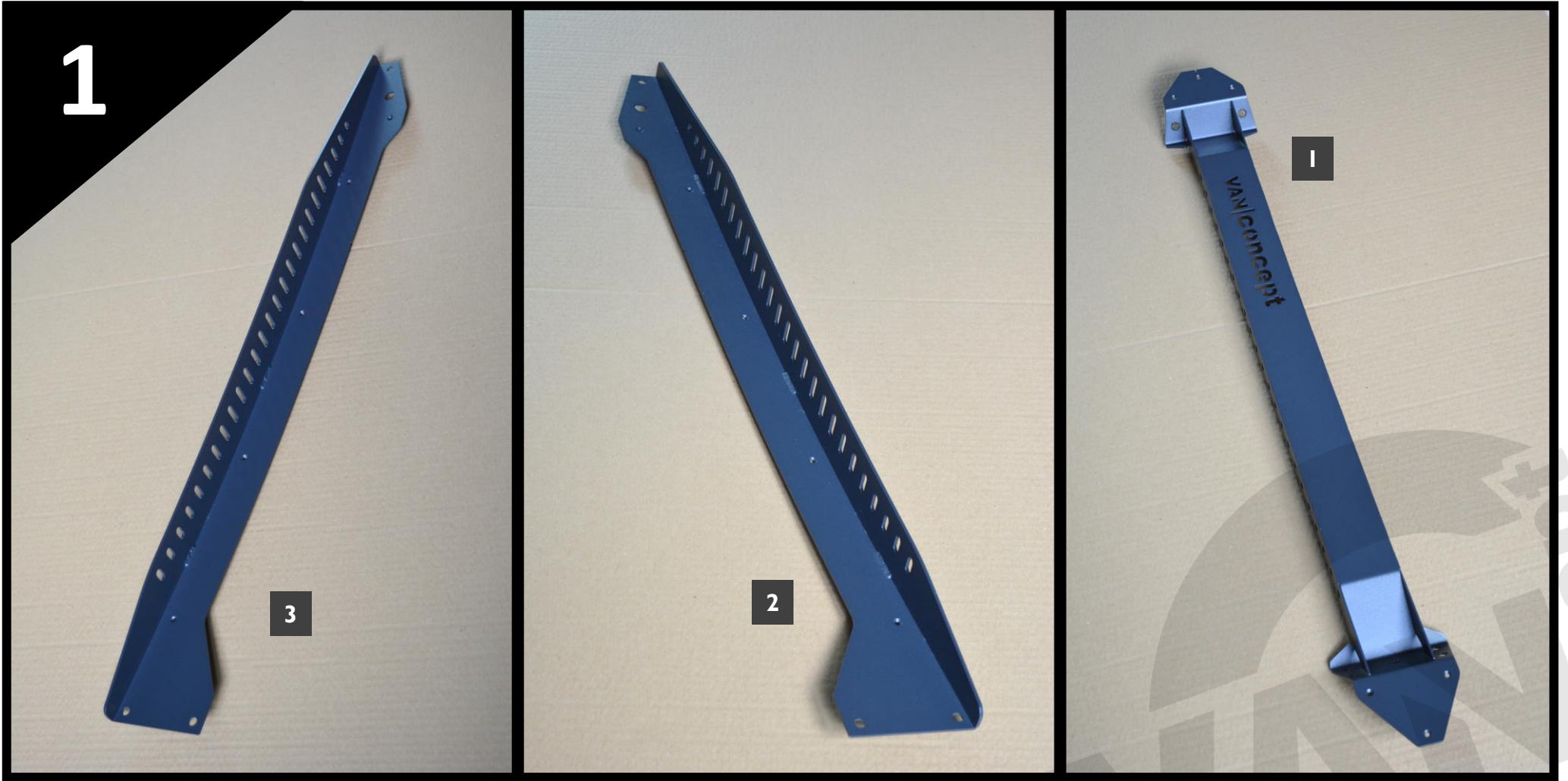

INSTRUCTIONS BED FRAME

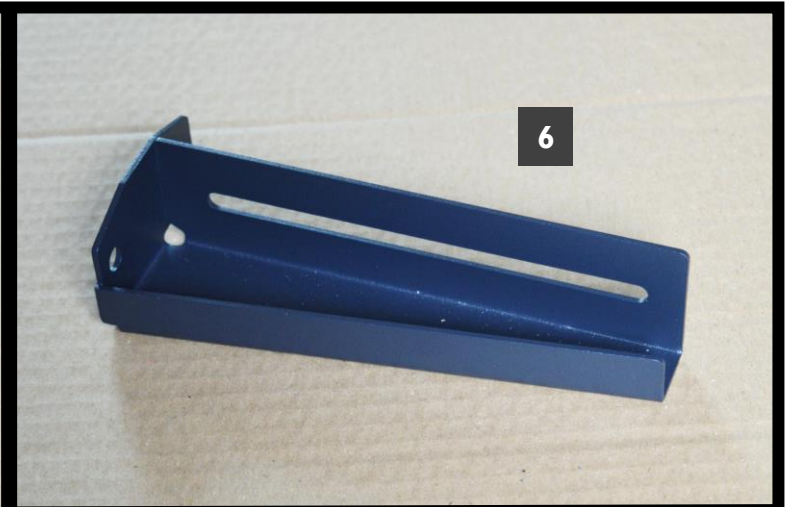

INSTRUCTIONS BED FRAME

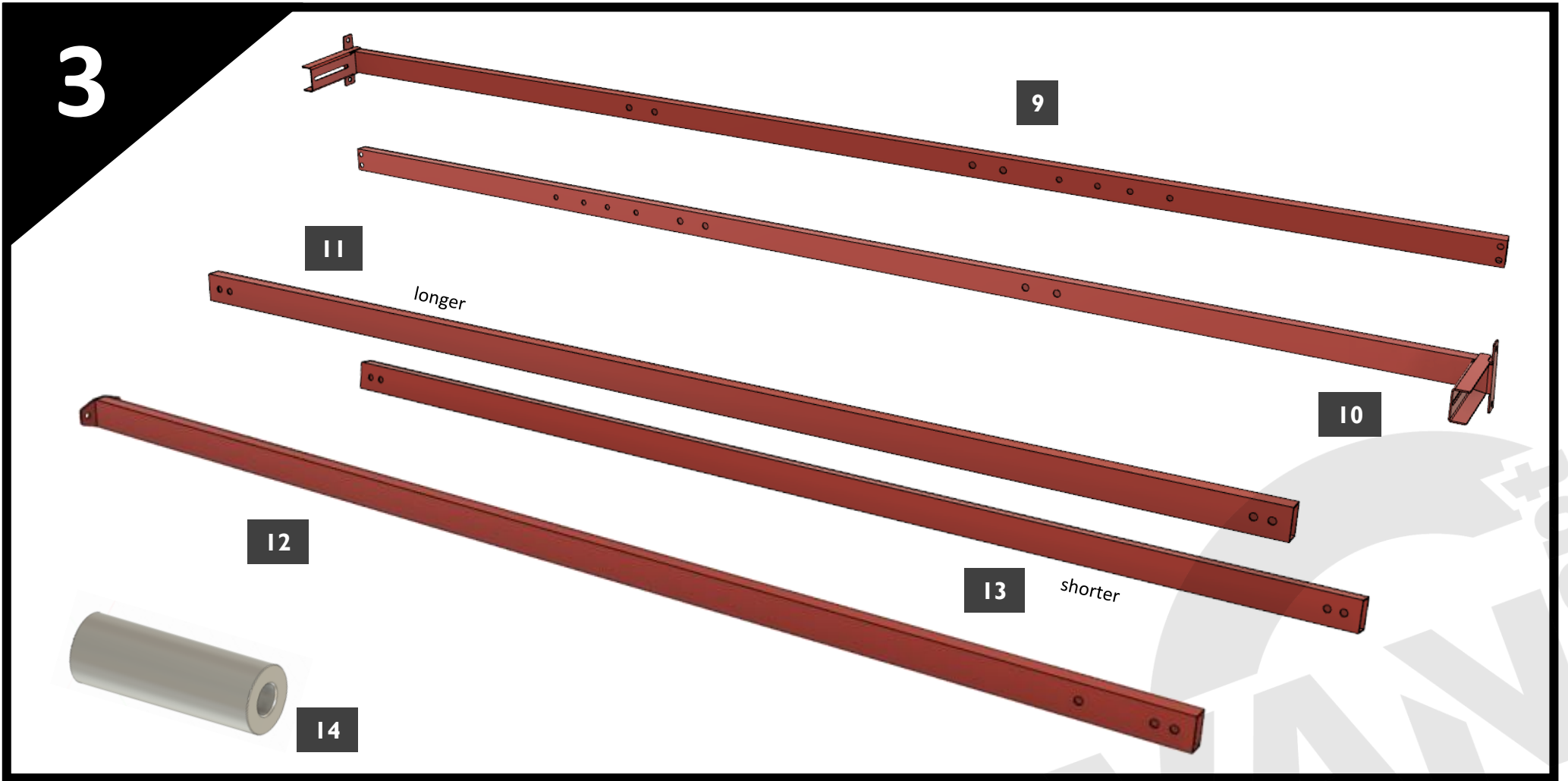

INSTRUCTIONS BED FRAME



- The completed bed frame assembly.

INSTRUCTIONS BED FRAME

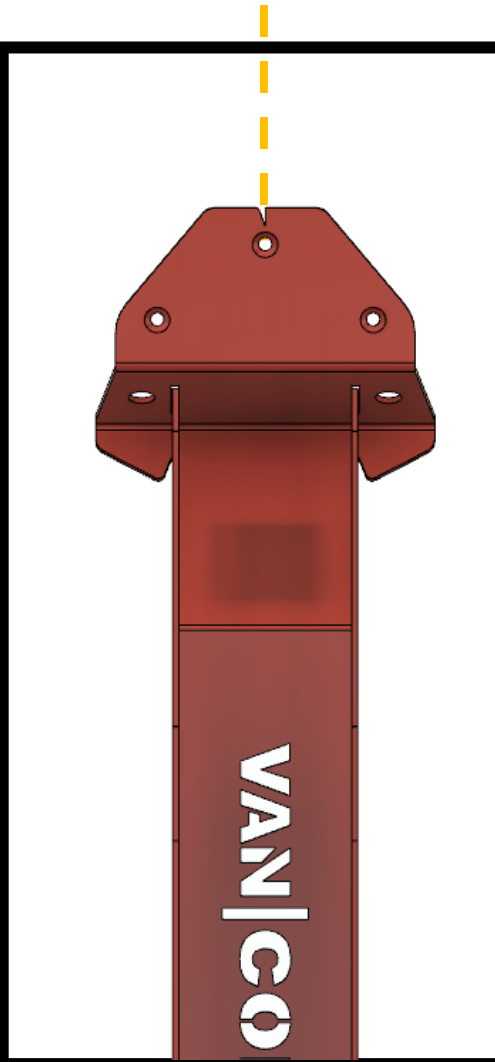

- For LWB vans, offer up 1x Bed Strut Vertical Front to the central recess (right hand side of van shown).
- Align the centre mark on the strut with the edge of the metalwork in the top section and temporarily fix the strut to the van using 2x 4.2 x 13mm self tapping screws through the rivet holes, one top and one bottom.
- *Use a square against the edge of the strut and align with the join in the upper metal panels to ensure a vertical fitment.*

INSTRUCTIONS BED FRAME



MWB FITMENT

- For MWB vans, offer up 1x Bed Strut Vertical Front to the rear recess (left hand side of van shown).
- Align the centre mark on the strut with the edge of the metalwork in the top section and temporarily fix the strut to the van using 2x 4.2 x 13mm self tapping screws through the rivet holes, one top and one bottom.
- *Use a square against the edge of the strut and align with the join in the upper metal panels to ensure a vertical fitment.*

INSTRUCTIONS BED FRAME

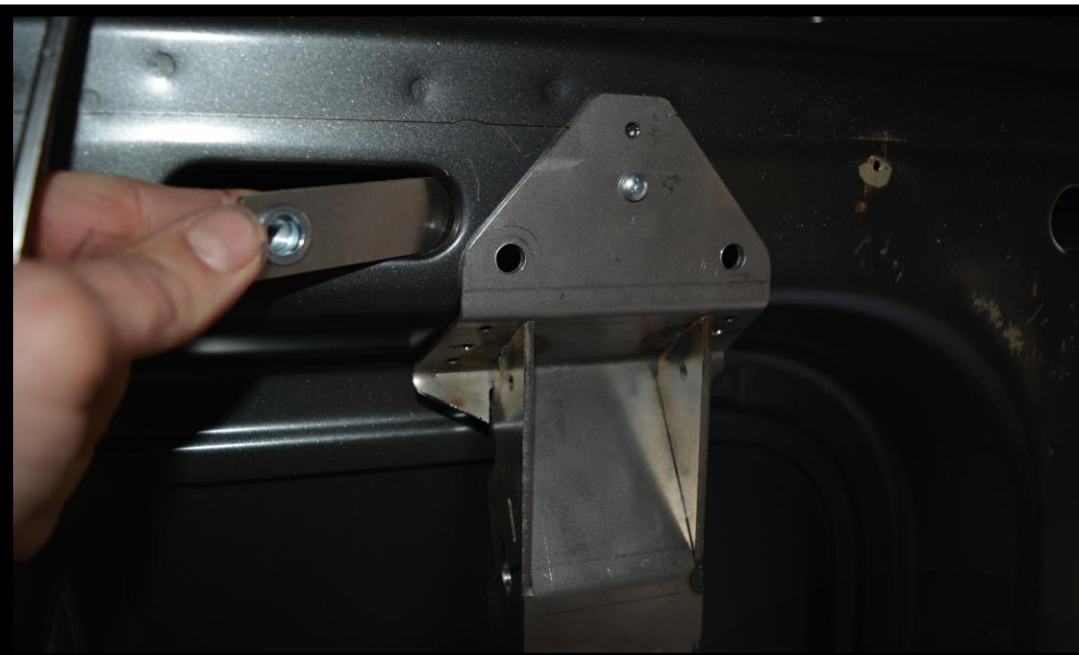

- Mark the position of the three lower (two won't be useable due to the hole in the bodywork) and two upper mounting holes, on the angled surfaces, along with the four remaining rivet holes, before removing the strut and drilling 4x Ø4.2mm and 5x Ø8.5mm holes, to match those in the strut. De-burr the holes and we advise applying some anti-corrosion paint to the bare metal.
- Re-fit the strut. For the top mounts, use 2x M8 x 20mm button head bolts and 2x M8 washers and tighten into Rivnut Plate A on the back of the bodywork, by accessing through the slot and for the bottom mounts, use 3x M8 x 20mm button head bolts and 3x M8 washers and tighten into Rivnut Plate B on the back of the bodywork.
 - Remove the self tapping screws and fit 6x countersunk rivets to pull the strut to the bodywork on the vertical surfaces. Ensure all three bolts are securely tightened.

INSTRUCTIONS BED FRAME



- Take the Bed Strut Vertical Rear RH and offer up to the rear corner of the van, aligning the hexagonal hole with the hole in the bodywork.
- Use a square against the short edge of the strut (see middle image) and align with the join in the upper metal panels to ensure a vertical fitment.
 - Temporarily fix the strut to the van using 1 x 4.2 x 13mm self tapping screw through the rivet hole at the top.

INSTRUCTIONS BED FRAME



- The rear strut is correctly aligned when the bottom edge is parallel with the bodywork.
- Mark the position of the two lower and one upper mounting holes, along with the four remaining rivet holes, before removing the strut and drilling 4x $\text{Ø}4.2\text{mm}$ and 3x $\text{Ø}8.5\text{mm}$ holes, to match those in the strut. *De-burr the holes and we advise applying some anti-corrosion paint to the bare metal.*
- Re-fit the strut, using 2x M8 x 20mm button head bolts and 2x M8 washers and tighten into Rivnut Plate A on the back of the bodywork, by accessing from underneath.

INSTRUCTIONS BED FRAME



- Fit 1x M6 x 20mm button head bolt with 1x M8 washer through the top mounting hole of the strut and bodywork, then fit 1x M8 penny washer and 1x M8 nyloc nut on the reverse.
- Remove the self tapping screw and fit 5x countersunk rivets to pull the strut to the bodywork.
 - *Ensure all three bolts are securely tightened.*

11



- Repeat the previous steps to fit the struts to the other side of the van.
- Choose the height of the bed frame and fit the Bed Mounting Brackets to each front strut, using 1x M8 x 80mm button head bolt and 2x M8 washers, 1x M8 nyloc nut and the M-0013 metal spacer between the two sides as shown. Do this on both sides of the bracket before fitting 2x rivets in the aligned holes.
 - Tighten both nuts securely.
- *Now is the best time to fit the ply lining to the van, with just a small cutout required to fit around the Bed Mounting Bracket.*

13



- Position the Side Beam in the Bed Mounting Bracket (left or right, easily identified by the angle on the rear bracket matching the angle of the rear strut) and fit 2x M8 x 20mm button head bolts and 2x M8 washers through the mounting holes at the rear of the Side Beam and into the slots on the rear strut.
 - Check the Side Beam is level and fit 2x M8 penny washers and 2x M8 nyloc nuts to the protruding bolt.
 - Fit the Side Beam on the other side in the same way

14



- Fit 2x M6 x 20mm button head bolts and 2x M6 penny washers through the slots in the Bed Mounting Bracket and tighten into the threaded boss in the Side Beam.
- With the rear still loosely fitted, ensure the two sides beams are parallel to each other and square, before tightening the nyloc nuts on the rear mounts.

15

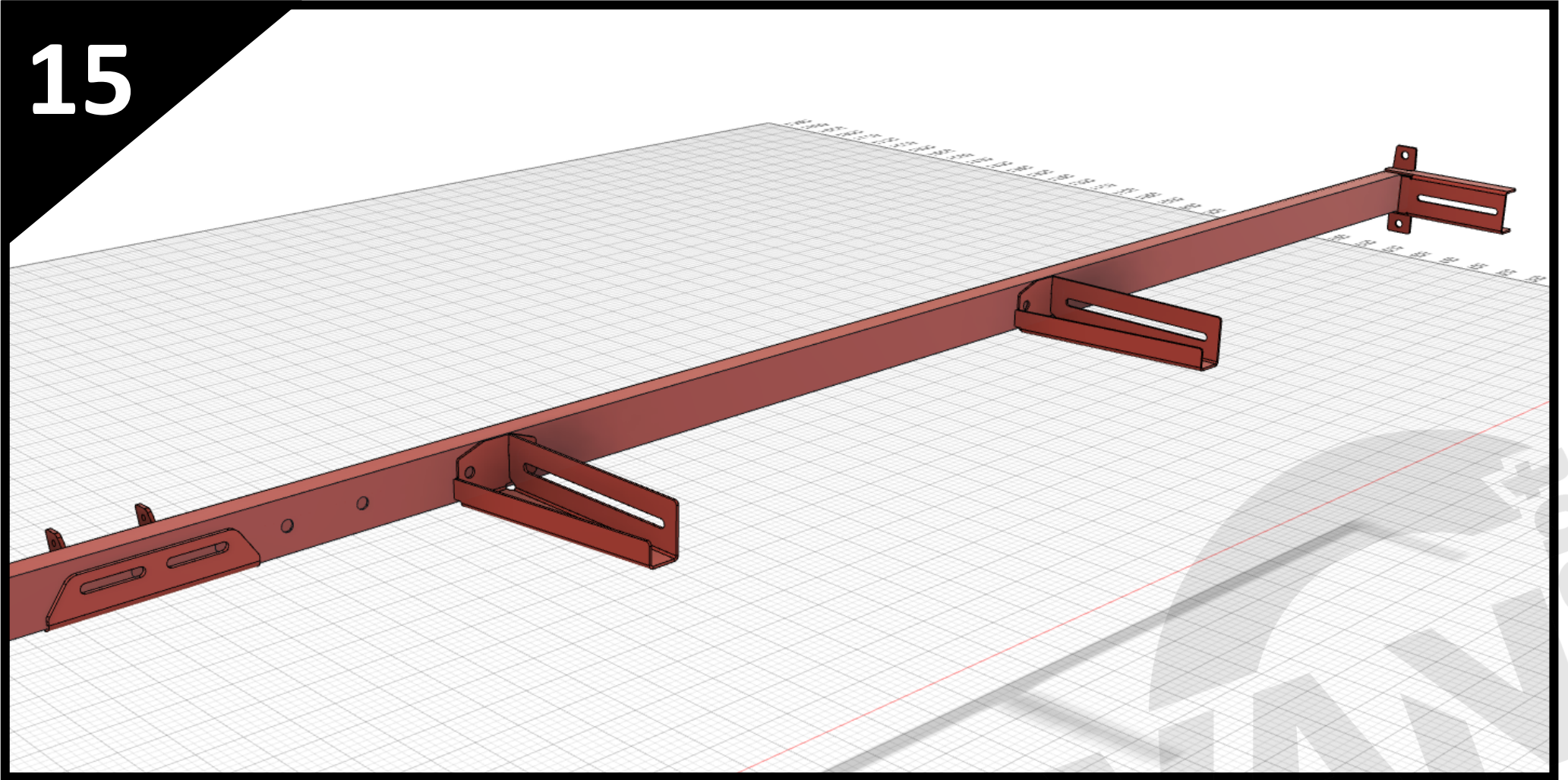

- Fit the two Central Bed Frame Brackets to either side beam and use 2x M8 x 20mm button head bolts and 2x M8 washers to secure in place.

16

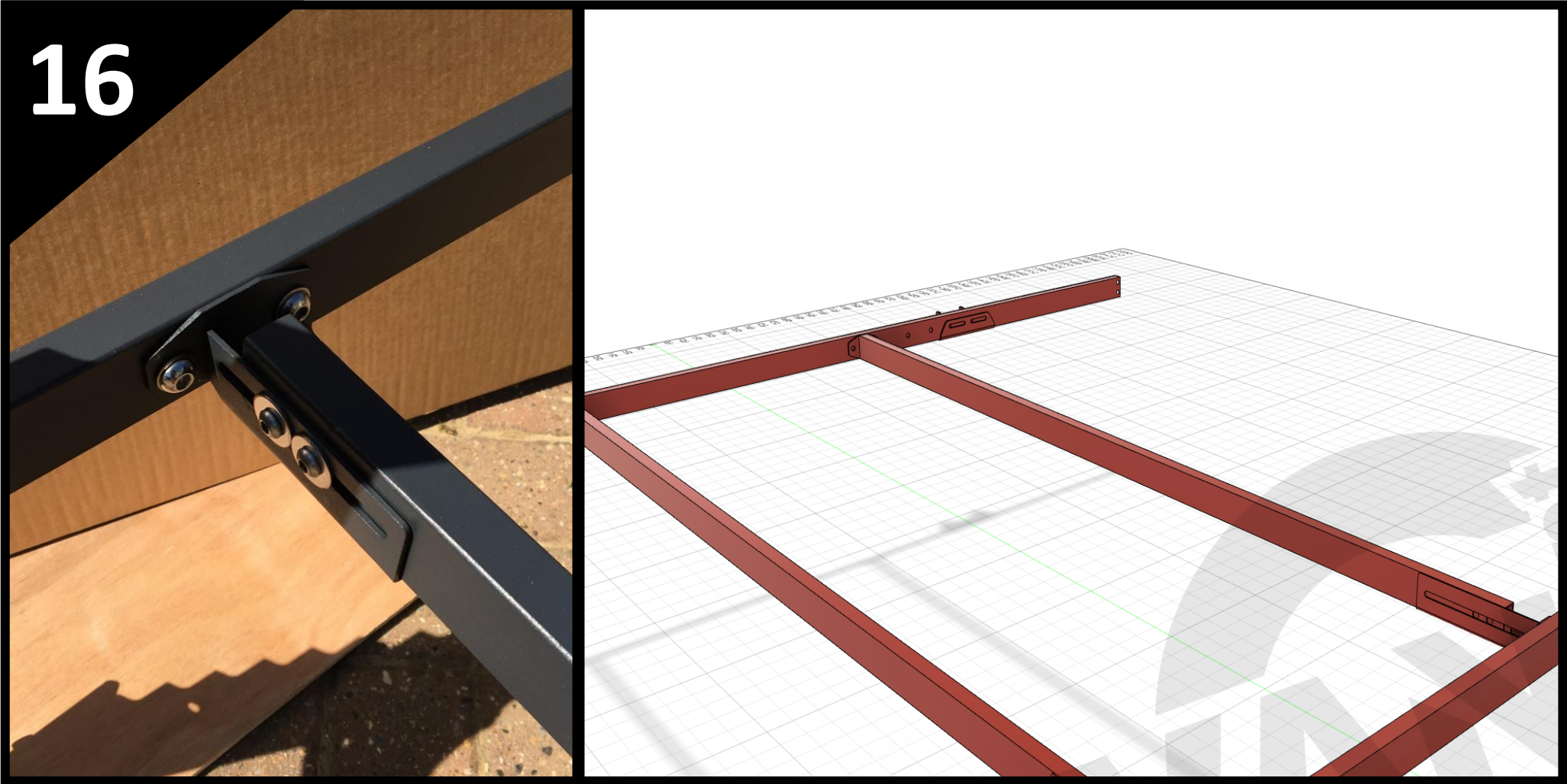

- Take both centre beams and position in the previously fitted bracket, before aligning the welded plate on the other end of the beam to the mounting holes in the opposite side beam. Fit 2x M8 x 20mm button head bolts and 2x M8 washers through the plate and tighten securely into the side beam.
- Take 2x M6 x 20mm button head bolts and 2x M6 penny washers and fit into two of the three threaded holes in the centre beam to the adjustable bracket, before tightening.



- If fitting the bed frame in the upper quarter of the height range, it may be necessary to shorten the two central rails.
 - If doing so, use a hacksaw and cut between the two outer holes as shown by the orange line above.
 - The remaining two threaded holes can be used to bolt the tube to the bracket.

18

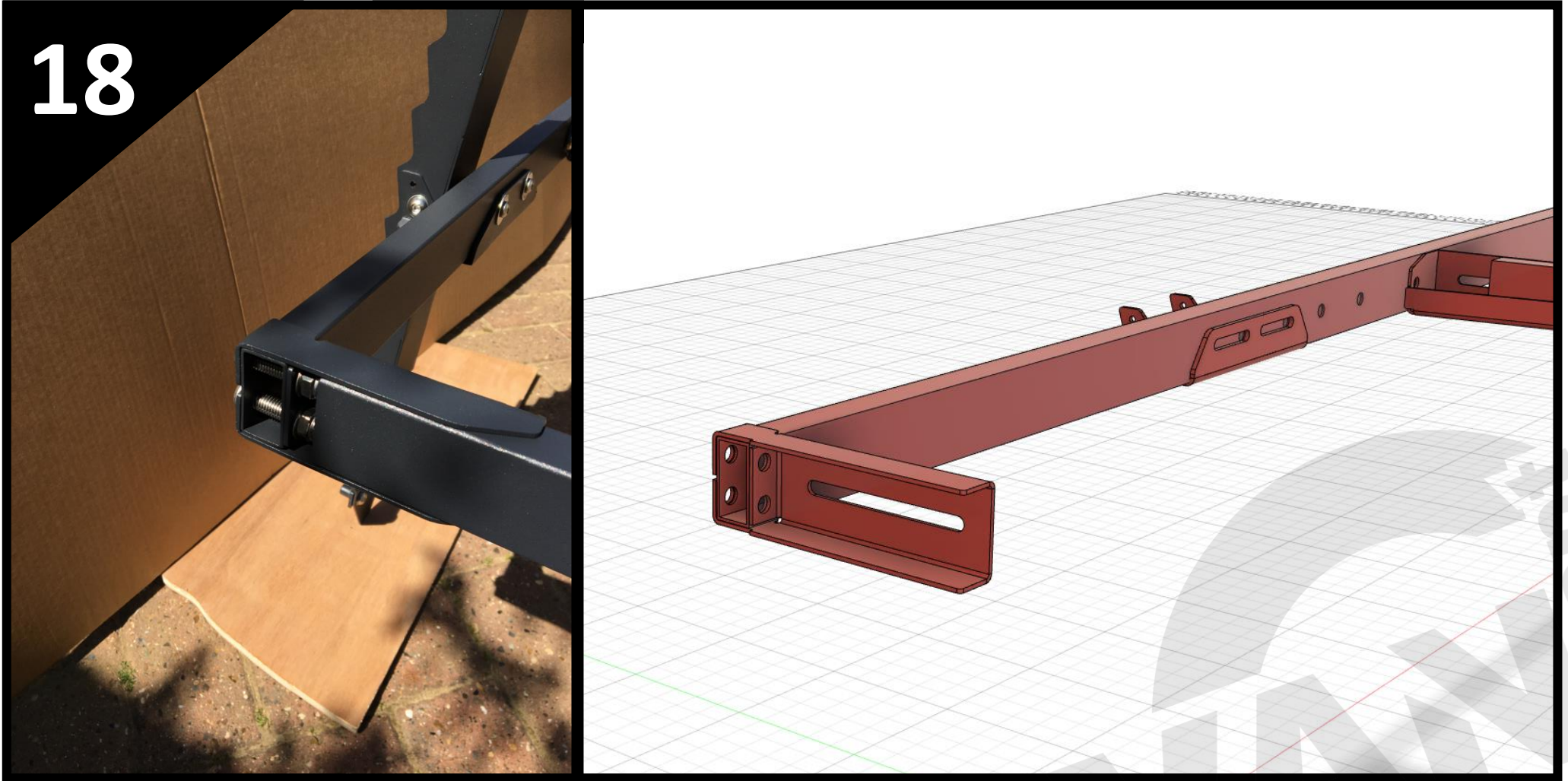

- At the front, position both the Bed Frame Bracket Front brackets over the ends of the Side Beams (note orientation), before fitting 1x M8 x 40mm button head bolt, with 2x M8 washers and 1x M8 nyloc nut through each hole, on both brackets as shown, before tightening.

19

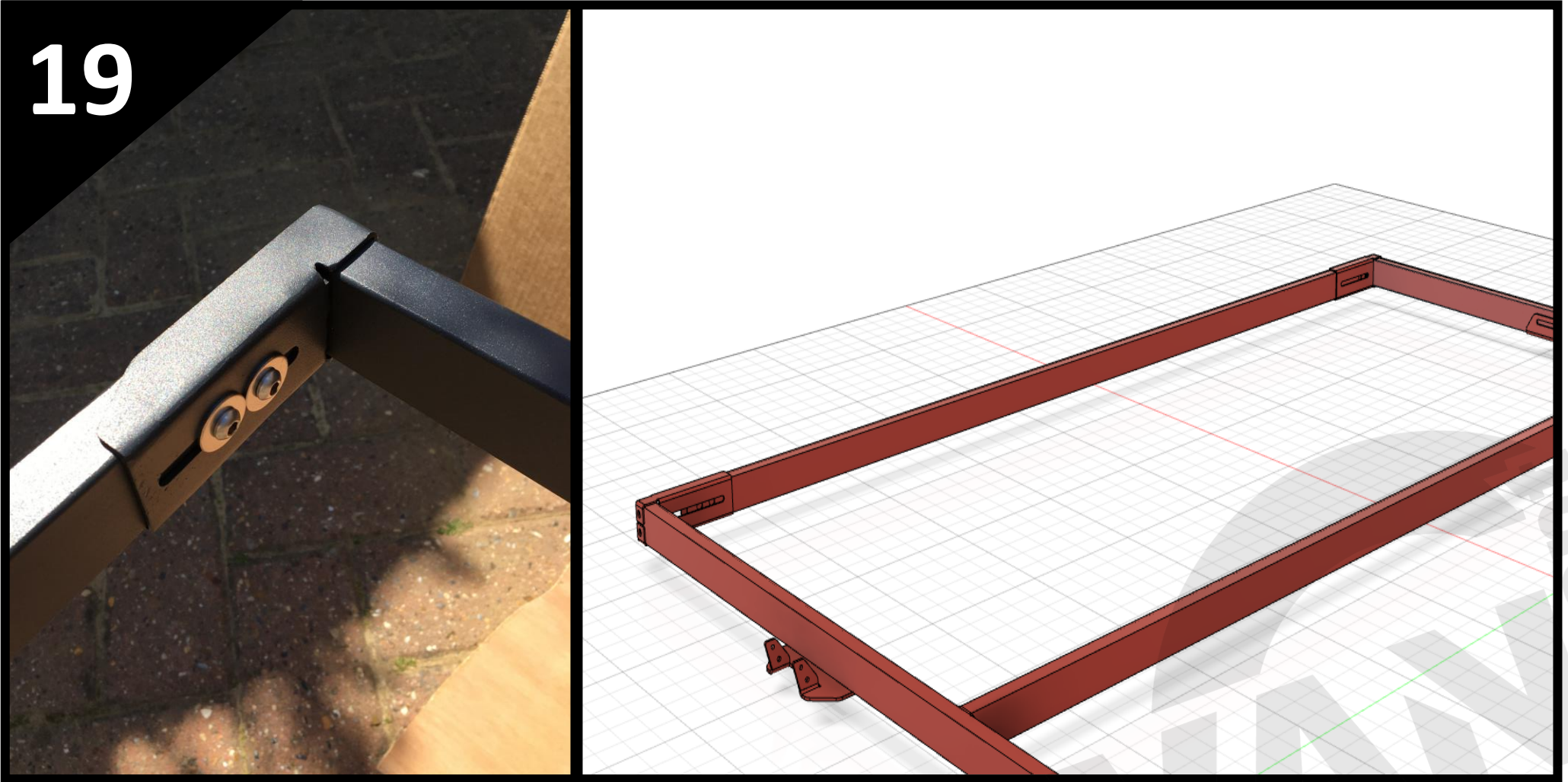

- Position the Front Beam in place and take 2x M6 x 20mm button head bolts and 2x M6 penny washers and fit through the slots on each side and into the threaded holes in the Front Beam.
 - Ensure the spacing is equal either side before tightening the bolts.

INSTRUCTIONS BED FRAME

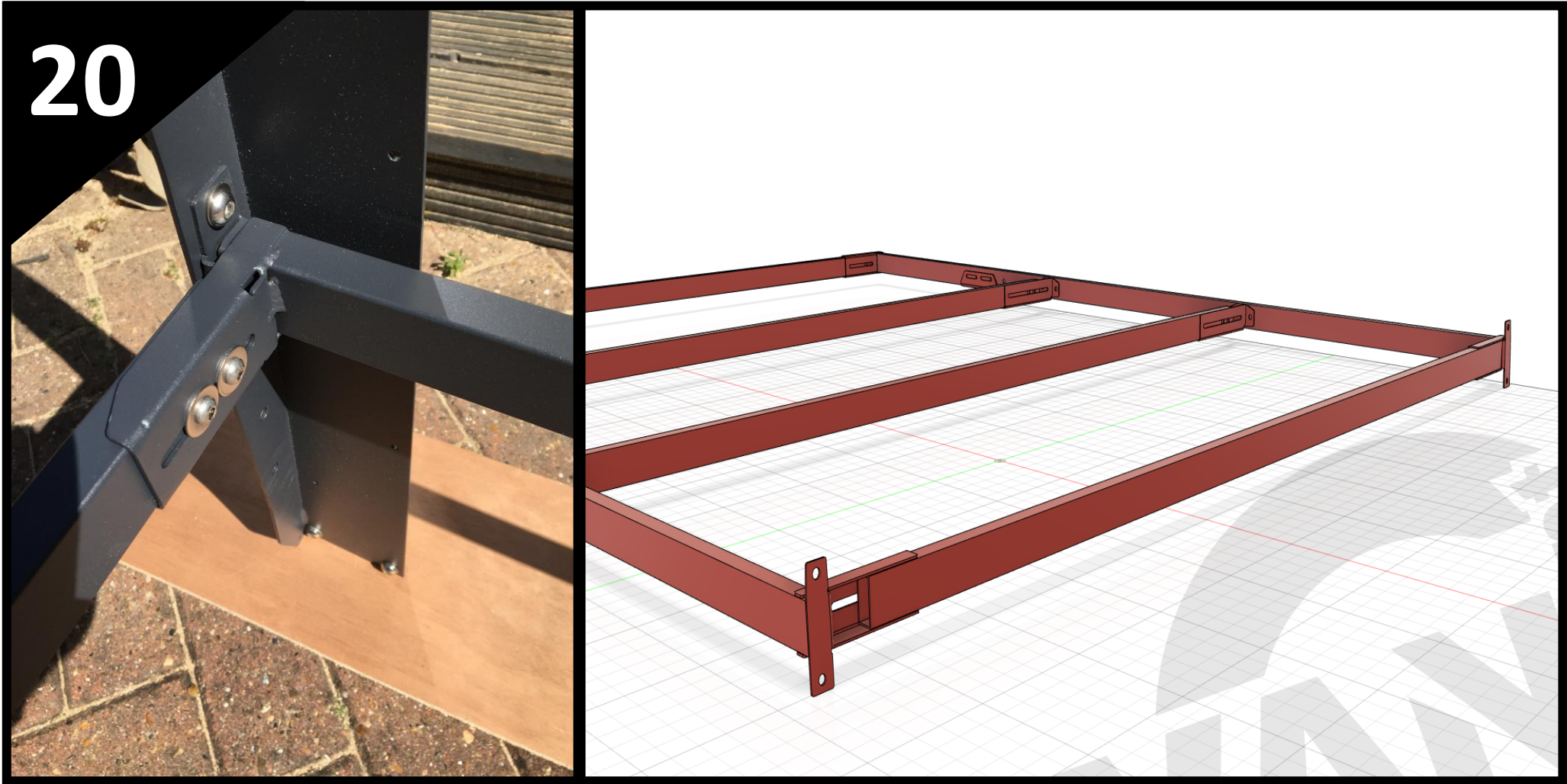

- At the rear, position the Rear Beam in place and take 2x M6 x 20mm button head bolts and 2x M6 penny washers and fit through the slots on each side and into the threaded holes in the Rear Beam.
 - Ensure the spacing is equal either side before tightening the bolts.

21



- Ensure all the bolts are tight and the bed frame is now fully fitted.
- A plywood base can be fitted to the metal frame, typically in two pieces due to sheet size, and screw down into the top face of the side beams using self drilling screws. We advise for the join between the two pieces of ply to be positioned over one of the beams.

22



- The bed frame has been designed so that it can be fitted at a multitude of heights. As the bed frame position rises, the overall width of the bed does become narrower due to the profile of the van.
- It's also easy to remove the central beams to maximise load space and we can supply the Bed Mounting Brackets separately, so more than one height can be pre-fitted, for maximum flexibility.